

# AH 740

ABSOLUTE HOLLOW SHAFT ENCODER

- Heavy Duty Construction
- Shaft Mounted
- Range of shaft bores (6 – 14 mm)
- Up to 12 Bits (8192) Maximum
- 5 Volt TTL or 8 to 30 Volts
- Gray Code or Binary Code



## ELECTRICAL SPECIFICATIONS

Supply Voltage	5 Volt or 8 to 30 V DC
Current Consumption	100 mA (max)
Output Circuit	Push-Pull, RS 422A
Impulse Frequency	200 kHz (max)
Logic Level (high)	Vcc - 0.7 Volt
Logic Level (low)	0.25 Volt (max)
Short Circuit Protection	100 %

## MECHANICAL SPECIFICATIONS

Cover	Aluminium
Body	Aluminium
Shaft	Stainless Steel
Speed	6000 RPM (max)
Torque	> 0.04 Nm
Loading	Axial 40 N, Radial 30 N
Protection	IP 65
Temperature	-20°...+70° C (-4°...+158° F) +100° C (+212° F) Optional
Weight	0.84 lb (380 g)

## OUTPUT SIGNALS

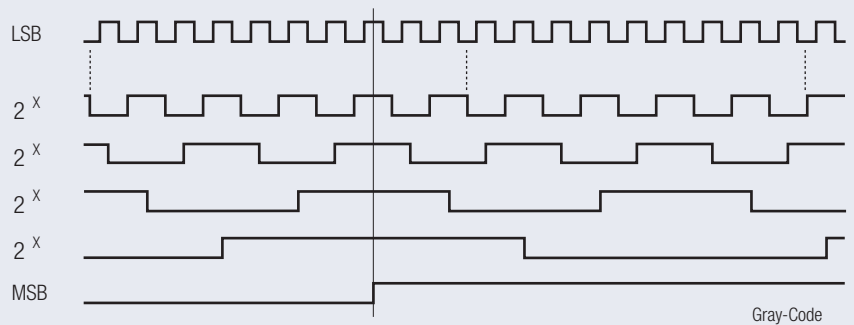

Drawing available as:  
dxf, iges, step, sld file

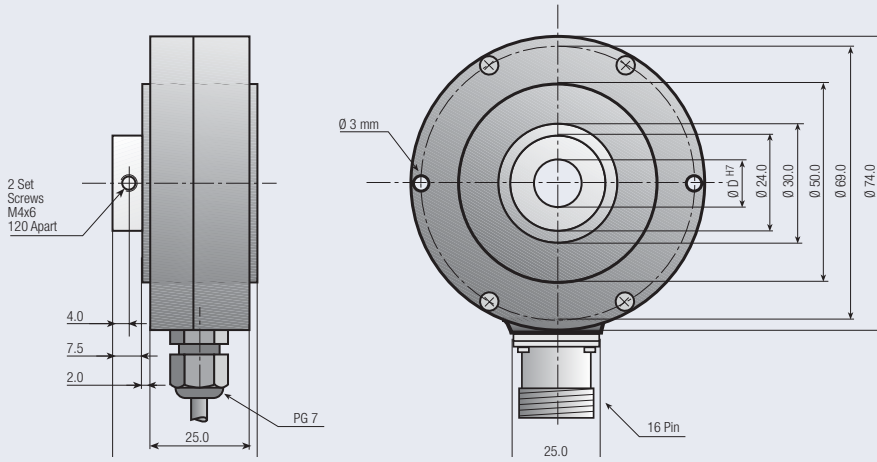

ORDERING CODE

**AH 740** -         -

a b c d e f g h Increments Per Revolution

- a** **Group Function**  
AH=Absolute Hollow Shaft
- b** **Basic Series Number**  
740
- c** **Shaft Size D**  
06=6 mm 10=10 mm 12=12mm  
14=14mm  
AA=1/4" AB=3/8" AC=1/2"
- d** **Mechanical Options**  
0=None

- e** **Connector Type**  
0=2 mtr. Cable  
8=16Pin
- f** **Connector Location**  
R=Radial
- g** **Output Signals**  
E=Binary <->  
F=Gray <->
- h** **Output Circuit Type**  
1=TTL (5 VDC)  
5=Push Pull 8 to 30 VDC

**Note:** Special functions and designs will be designated by a 4 digit code at the end of the part number. Consult factory for further details

CONNECTIONS

Function	16 Pin Connector	Cable Colour Code	Function	16 Pin Connector	Cable Colour Code
0 Volt	1	white	2 <sup>6</sup>	9	black
+ Volt	2	brown	2 <sup>7</sup>	10	violet
2 <sup>0</sup>	3	green	2 <sup>8</sup>	11	grey/pink
2 <sup>1</sup>	4	yellow	2 <sup>9</sup>	12	red/blue
2 <sup>2</sup>	5	grey	2 <sup>10</sup>	13	white/green
2 <sup>3</sup>	6	pink	2 <sup>11</sup>	14	brown/green
2 <sup>4</sup>	7	blue	2 <sup>12</sup>	15	white/yellow
2 <sup>5</sup>	8	red	<->	16	yellow/brown