

AS 700

ABSOLUTE SHAFT ENCODER

- Heavy Duty Construction
- IP65 Protection
- Up to 13 Bits (8192) Maximum
- 8 to 30 Volts or RS 422A Compatible
- Gray Code or Binary Code
- Optional Reset

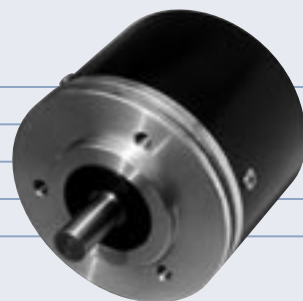

ELECTRICAL SPECIFICATIONS

Supply Voltage	5 Volt or 8 to 30 V DC
Current Consumption	100 mA (max)
Output Circuit	Push-Pull, RS 422A
Impulse Frequency	500 kHz (max)
Logic Level (high)	Vcc - 0.7 Volt
Logic Level (low)	0.25 Volt (max)
Short Circuit Protection	100 %

MECHANICAL SPECIFICATIONS

Cover	Aluminium
Body	Aluminium
Shaft	Stainless Steel
Speed	6000 RPM (max)
Torque	> 0.1 Nm
Loading	Axial 60 N, Radial 50 N
Protection	IP 65
Temperature	-20°...+70° C (-4°...+158° F) +100° C (+212° F) Optional
Weight	0.99 lb (450 g)

OUTPUT SIGNALS

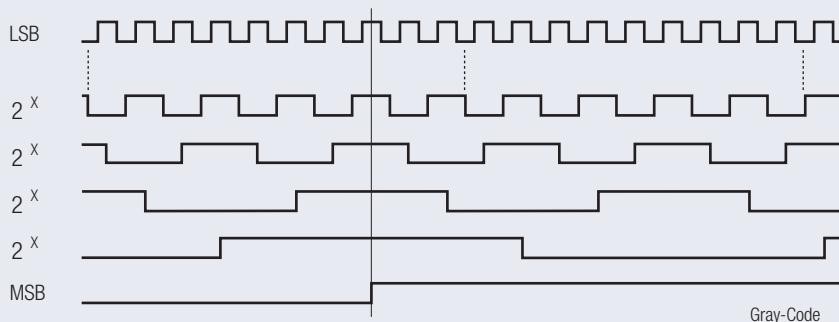

Drawing available as:
dxf, iges, step, sld file

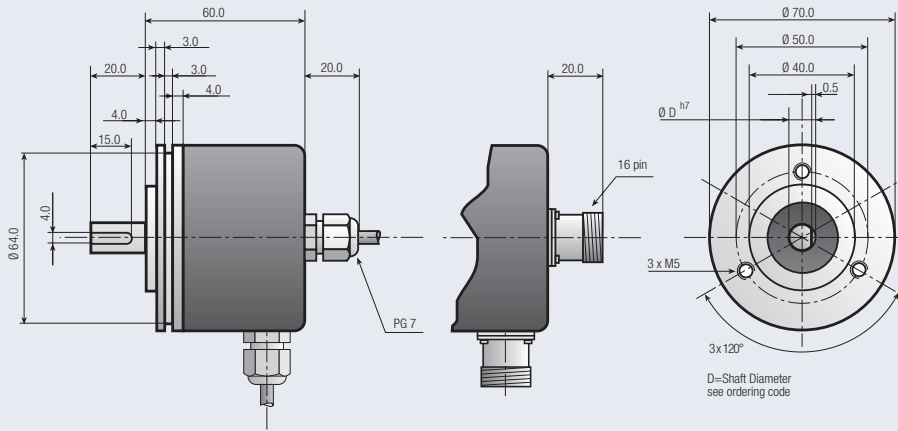

ORDERING CODE

AS 700 - -

a b c d e f g h Increments Per Revolution

- a **Group Function**
AS=Absolute Solid Shaft
- b **Basic Series Number**
700
- c **Shaft Size D**
10=10 mm
12=12 mm
AC=1/2"
- d **Mechanical Options**
0=None

- e **Connector Type**
0=2 mtr. Cable
8=16Pin
- f **Connector Location**
A=Axial
R=Radial
- g **Output Signals**
E=Binary <->
F=Gray <->
- h **Output Circuit Type**
1=TTL (5 VDC)
5=Push Pull 8 to 30 VDC

Note: Special functions and designs will be designated by a 4 digit code at the end of the part number. Consult factory for further details

CONNECTIONS

Function	16 Pin Connector	Cable Colour Code	Function	16 Pin Connector	Cable Colour Code
0 Volt	1	white	2 ⁷	10	violet
+ Volt	2	brown	2 ⁸	11	grey/pink
2 ⁰	3	green	2 ⁹	12	red/blue
2 ¹	4	yellow	2 ¹⁰	13	white/green
2 ²	5	grey	2 ¹¹	14	brown/green
2 ³	6	pink	2 ¹²	15	white/yellow
2 ⁴	7	blue	Reset	-	yellow/brown
2 ⁵	8	red	<->	16	white/gray
2 ⁶	9	black	Earth	-	striped